

# SMEDEGARD OF DENMARK

## ❖ Installation Guide

### OmegaDrive

HV 3.15 – 3.22

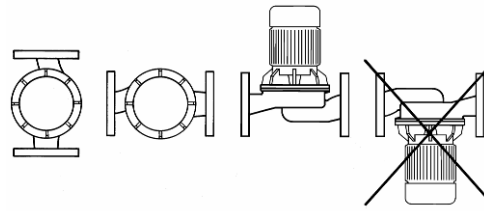
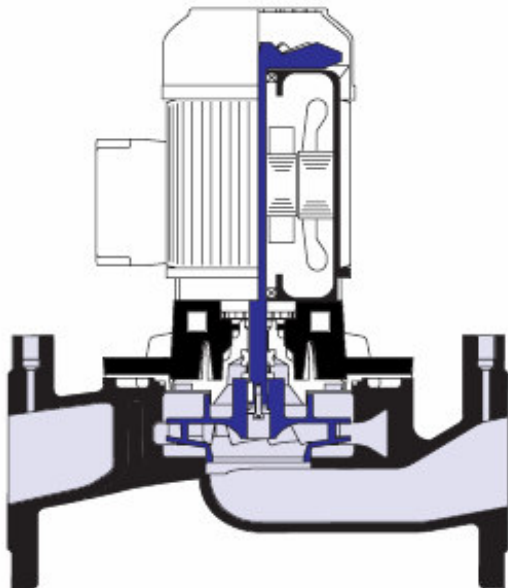
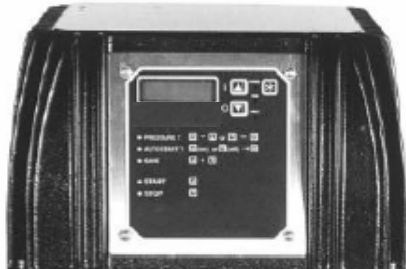

Fig. 1 Pump Installation

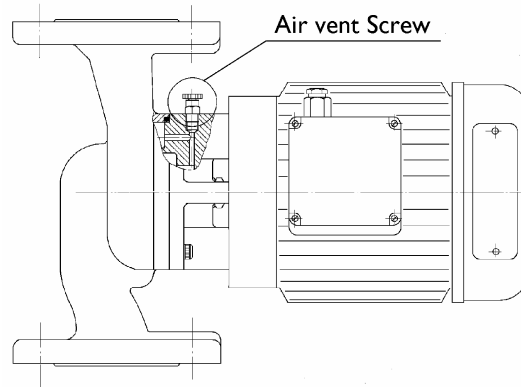

Fig. 2 Air venting

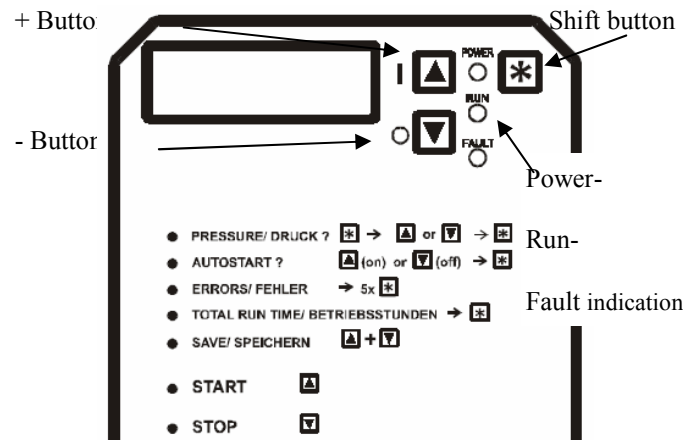

Fig. 3 Operating panel

Power supply  
3\*400V

Motor-connection  
U  
V  
W

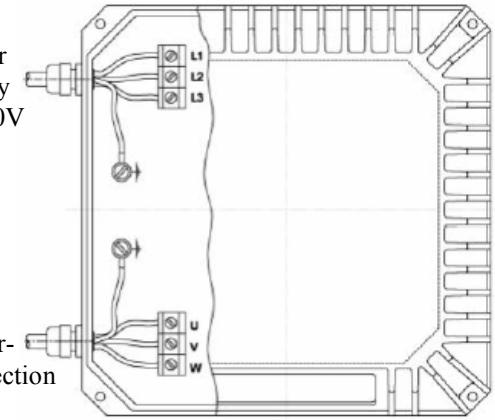

Fig. 4 Installation overview for HV 3.15 – 3.22

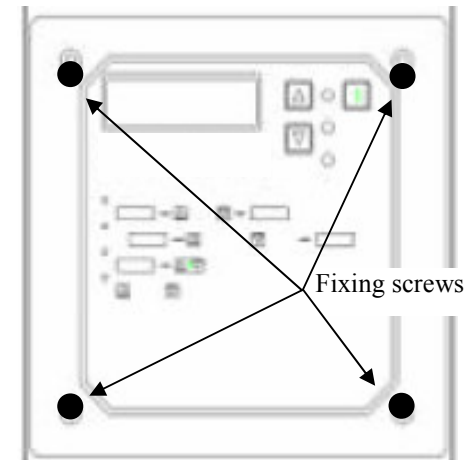

Fig. 5 Fixing screws

## Installation Guide OmegaDrive

This installation guide gives basic instructions which are to be observed during installation, operation and maintenance of the pump. It is therefore imperative that this manual be read by the responsible person/operator prior to the installation and should always be kept available at the site. It is not only the general safety instructions under this main heading "Safety" that are to be observed but also the specific information provided under the other main headings.

**Serial No.:** See nameplate

### Construction and application

Smedegaard Omega-Range pumps are of the in-line construction with the motor mounted directly to the pump body. The pumps are suitable for commercial and industrial heating systems, district heating schemes, water treatment plants, general water transfer duties and refrigeration plants

### Pump medium



Clean, thin non-aggressive and non-explosive fluids without any solids or fibres. Antifreeze without any mineral oil (special model upon request).  
Kinematics viscosities: Max. 10 mm<sup>2</sup>/s.

**Please note:** If any liquid other than water is being pumped, we recommend that you contact **T. Smedegaard A/S** or their representatives as pump characteristics may change.

### Technical Data

Electrical data: See nameplate  
Max. working pressure: 10bar  
NPSH requirements: 82°C: 4-5 mVs  
NPSH requirements: 95°C: 5-7 mVs  
Water temperature range: -15°C to +120°C

### Safety

	<ul style="list-style-type: none"> <li>- The surface temperature of the pump including inverter might be hot! When venting the pump (fig,2) or when a mechanical seal is defective, it could result in an escape of hot water or steam!</li> <li>- Beware of rotating parts!</li> </ul>
	<ul style="list-style-type: none"> <li>- Pump should be wired in line with the existing regulations</li> <li>- The main electrical supply must be isolated before any work is carried out on the pump.</li> <li>- The pump must be properly earthed or relay protected (HPFI).</li> </ul>

### Personnel qualification and training.

Personnel responsible for operation, maintenance, inspection and installation of the pump must be in possession of the necessary qualifications for this kind of work  
Furthermore the owner should assure that the contents of the operation manual, is understood by the personnel.

### Airborne Sound pressure level

6-pole motors ( 950 rpm):  
Max. 63 dB(A)

4-pole motors(1450 rpm):  
0,75 kW to 1,5 kW, max. 50 dB(A).  
3 kW to 7,5 kW, max. 58 dB(A).  
11 kW to 22 kW, max. 69 dB(A).

2-pole motors (2900 rpm):  
0,55 kW to 3 kW, max. 61 dB(A).  
4 kW to 11 kW, max. 69 dB(A).  
15 kW to 22 kW, max. 79 dB(A).

Complying to EN 12639.

### Installation

1. The pump must be installed as shown in Fig. 1. Direction of flow through the pump casing is indicated by an arrow.
2. If it is required to turn the motor , take care that the "O" ring between pump casing and motor is placed correctly before tightening the bolts.
3. The cooling profile should never be covered. Also take care that the room is vented sufficiently for maximum cooling effect..
4. Ensure pipe work alignment is correct and the pump and pipe work are adequately supported. Sharp bends should be avoided adjacent to the pump.
5. If pump is mounted in vertical pipe work, flow should be upwards. If flow is downwards, an air-vent must be fitted at the highest point before pump suction. .
6. To avoid accumulation of impurities in the pump, ensure that it is not mounted at the lowest point in a system.
7. System should be thoroughly flushed out to clear any solder, steel wool, plaster or any other foreign matter that may be lodged in the pump.

## Electrical connection

The Omega pumps must be installed with overload protection. The OmegaDrive pumps have incorporated overload protection. The pumps must be connected according to local electrical regulations. See installation guide and wiring diagram in motor terminal box.

## Air venting

Open valves on suction and discharge side, allowing water to enter the pump casing. Open the air vent screw on the pump seal chamber (see fig. 2) and allow all the air to escape. Close the air vent screw.

## Starting

### **WARNING: The pump must not run without water.**

Open the suction valve and close discharge valve. Start the pump and slowly open the discharge valve until fully open.

The pump should never be allowed to operate for a long period in a closed valve condition.

## Connection overview

Transmitter, operating – fault indication connection is shown in the drawing below.

The drawing is illustrating the control terminals in the inverter head. (see also Fig.3 and Fig4.).

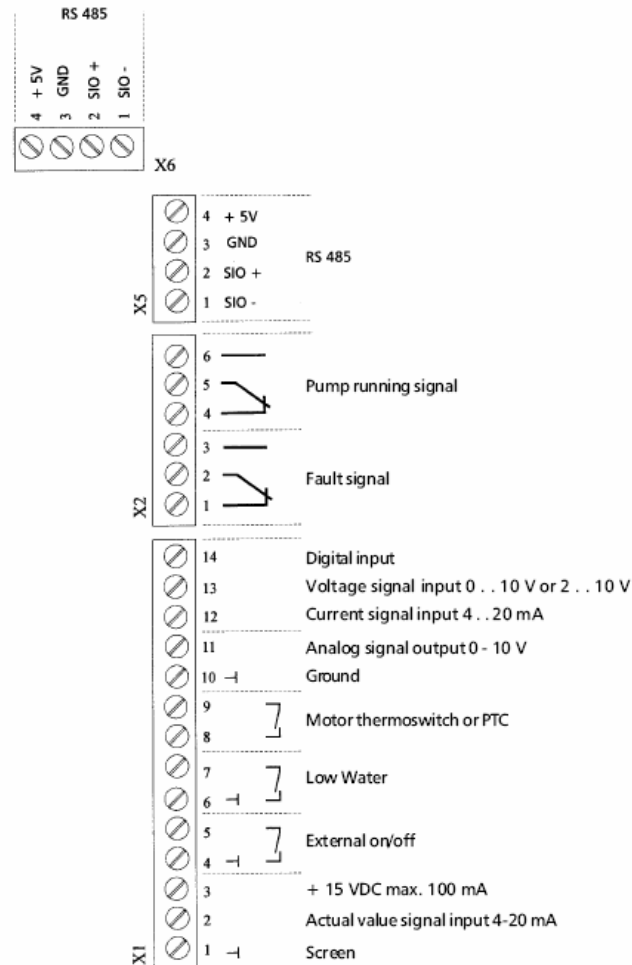

Fig. 6 Connection overview

## Functional overview

As shown in Fig. 3 the control unit has a LCD display and three push buttons (+, - and \*).

The Control has a wide range of functions :

- Manual frequency setting
- Friction compensation
- Constant pressure regulation
- Differential pressure read out (bar, psi, %)
- Frequency display
- Mail function display
- Manual operation
- Multiple pump operation (Regulation of several pumps in cascade configuration).
- Synchronised operation (All pumps are working at the same time).
- Analogue input-/slave operation (SRO operation)
- Alternating mode
- Ramp regulation
- Low water protection
- Relay for pump running signal
- Relay for pump fault signal
- Analogue display of frequency
- Dual set point mode
- External on/off
- Set point protected by password
- Damp/moisture protected control unit
- Test programme for pump start up
- Language selection [German, English, Italian, French, Spanish, Portuguese or Dutch]

The OmegaDrive is programmed to cover a wide range of typical working situations. The pump is set for single operation, maintaining the set differential pressure.  
 The minimum frequency is set to 20Hz.  
 The language is set to English.

The control unit has two menu levels. The first menu system is the operator menu (see this page), for the adjustment of the duty point. In addition you also have a full set up menu (see at the back of this manual) for all advanced settings. In this menu you can adjust ramp regulation, multiple pump operation, cascade and external regulation.

For a complete description of all possible settings refer to the “Operating instruction, Hydrovar 3.15 – 3.22

### Language selection

When the power is switched on you can change the language for the inverter.  
 Pressing the \* and + buttons the menu for language selection is shown and the required language can be selected using the + and – buttons. For acceptance press the \* button.

### Operator menu

The pump is already pre-set from the factory making commissioning easy. The only parameter typically to change is the required set point.

The set point can easy be changed pressing the \*-button once or until the display show

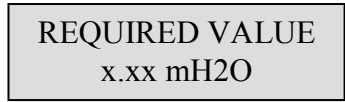

Adjustment of the required differential pressure is achieved by pushing the + or- buttons and the pump will then regulate the system pressure to the new set point values. The adjustments are saved by pressing the \* button eight times or until the display shows



The new value for the set point is saved pressing the + and – button simultaneously.

During operation you can start or stop the pump and display the actual differential pressure, set point for the auto start, the last 5 errors registered and total operating time.

Use the + or - buttons to change the menus.  
 The flow chart gives you an overview of the operator menu.

### Operator menu

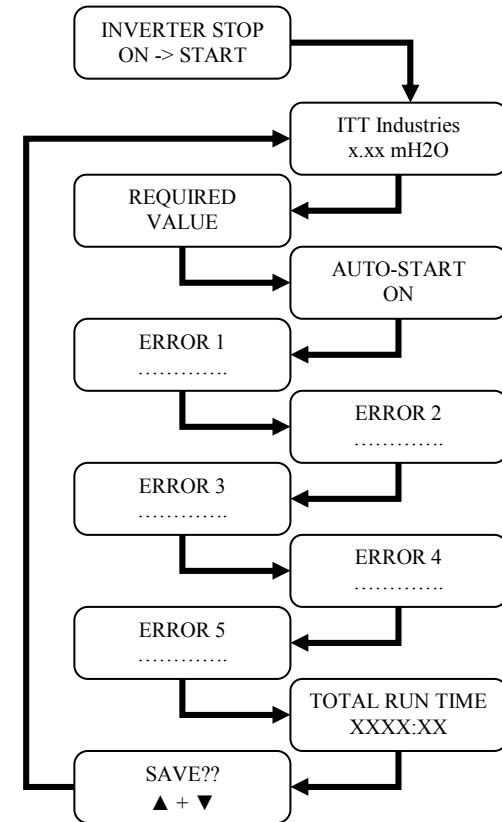

## Programming for Analogue/slave operation

Connect the external signal to 1 and 2 in the X1 terminal block – see Fig.6. The control unit must be set for external input, by changing the control setting.

The control unit must be set for external input. It is required to change the control setting. When the operator menu is in the standard position and displays

ITT INDUSTRIES  
x.xx mH2O

Press the \* button for 3 seconds until the display changes to

PASSWORD  
0000

The factory setting for the password is 0066. You can change the password using the + or – buttons and save with \* button.

The control unit is now in the set up menu. Press the \* button (15 times) until you reach

Mode  
XXXXXXXX

Press + or – button to select the different control modes until you read

Mode  
Actuator

Press the \* button until the menu says SAVE

SAVE??

▲ + ▼

Press simultaneously the + and – button. The control unit is now set to a 4 to 20 mA input signal regulating the motor between the minimum and the maximum frequency.

As the pump is now controlled by an external signal the following safety settings are maintained:

- Ramp up values
- Minimum frequency
- Thermal protection
- External start /stop relay

## Multiple Pump Operation and Control

You can have multiple pump control for cascade, parallel and a combination of these two working conditions

When operating multiple pump control, one pump will try to hold the set point. If this is not possible the next pump will start and try to hold the set point together with the first pump. If two pumps are not sufficient to hold the set point the next pump will start and so on.

All pumps in the group will act as the main pump, second pump, third pump etc. so that all pumps have the same number of operating hours.

Only three changes in the menu are required to operate each of the OmegaDrive pumps in multiple pump control. In addition you need a communication cable between the pumps.

NB: The pumps must use the same sensor range.

## Wiring:

The communication wire must be a 3-lead, shielded cable and connected to the terminal block X5 or X6 connected to 1, 2 and 3 (Fig. 7).

## Programming:

All pumps must be set for multiple pump operation each pump having its own unique address and set to receive the set point from the master pump.

## Multiple pump control

All pumps must be set for multiple pump operation

Mode  
Controller

Change the setting from “Controller” to “Multi controller”

Mode  
Multi controller

## Set point selection

All “slave pumps” must be set to receive the set point from the master pump

Source Req. Value  
OFF

This is the fifth sub- menu to the menu

SUBMENU  
Seq Control

Adjust all “slave pumps” to receive the set point from address 1.

Source Req. Value  
Adr 1

### Pump address

The pump address can be set at the menu,

Pump – Address  
off

This is the first sub menu in the menu.

SUBMENU  
RS 485 - Interface

The master pumps address must be address No.: 1. All the other pumps will have address 2, 3, or 4. Each address can only be used once.

### Time intervals for cascade operation

The time duration for the working time of the master pump is set in

Switch interval  
24 Hours

This is the fourth sub menu in main menu.

SUBMENU  
Seq Control

The menus required for the OmegaDrive to adjust for multiple pump operation, are marked (1), (2), (3) and (4) on the operators menu overview.

### Declaration of Conformity:

We SMEDEGAARD A/S, Sydvestvej 57-59,  
DK-2600 Glostrup hereby declare that our product OmegaDrive  
H.V.1.1 – 1.2 is in conformity with:

- Council Directive 72/23 CEE as modified by Directive 93/44  
CEE on the approximation of the laws of the Member States  
relating to Electrical equipment designed for use within certain  
voltage limits.

- Council Directive 89/336 CEE on the approximation of the  
laws of the Member States relating to Electromagnetic  
Compatibility

- Council Directive 82/392 on the approximation of the laws of  
the Member States relating to construction and making of  
Machines.

### EN standards used:

EN 292 part 1+2, PrEN 809, EN 50081-1 og EN 50082-2,  
EN 50178, EN 60146, En 50178 og EN 60204-1.

Glostrup, 2005



ITT INDUSTRIES  
X.XX mH2O

Change between menus press \*-button  
Change to submenu press \*-button for >3 seconds.

Password = 0066

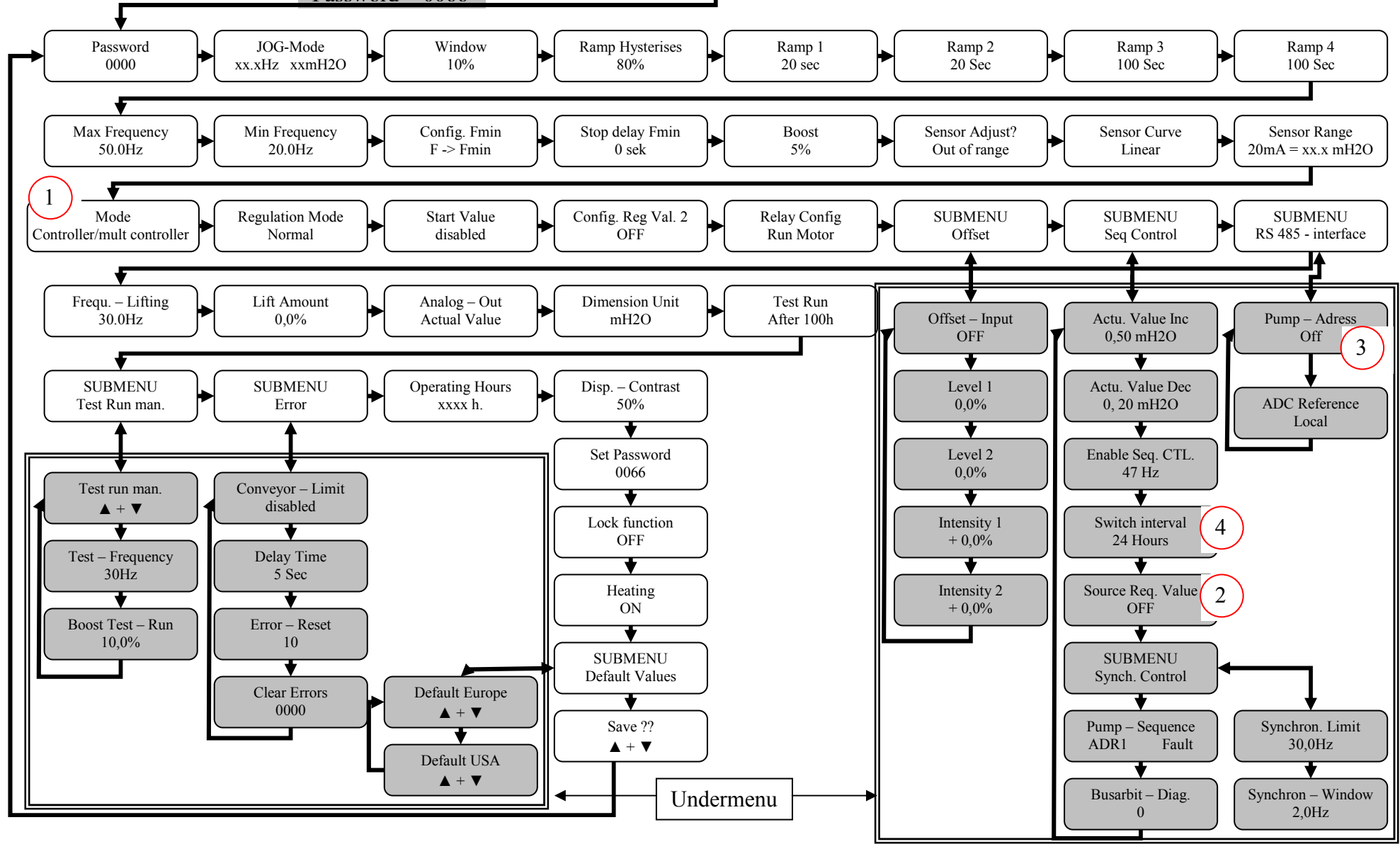

1

3

4

2